



# **Lexical Analysis (Practice)**

## **ICS312 Machine-Level and Systems Programming**

Henri Casanova ([henric@hawaii.edu](mailto:henric@hawaii.edu))

# (q1) Write a Regex

- Write a regular expression for “All strings over alphabet {a,b,c} that consist of one or more a’s, followed by two b’s, followed by whatever string of a’s and c’s in any order”?

# (q1) Solutions

- Write a regular expression for “All strings over alphabet {a,b,c} that consist of one or more a’s, followed by two b’s, followed by whatever string of a’s and c’s in any order”?

$a^+ b b (a | c)^*$

## (q2) Select a Regex

- Which of the REs below correspond to “All strings over alphabet  $\{a,b,c\}$  such that they contain at least one of substrings ‘abc’ or ‘cba’”?
  - **#1:**  $(abc)^+ \mid (cba)^+$
  - **#2:**  $(a \mid b \mid c)^* (a \mid c) b (a \mid c) (a \mid b \mid c)^*$
  - **#3:**  $(a \mid b \mid c)^* (a b c) (c b a) (a \mid b \mid c)^*$
  - **#4:**  $(a \mid b \mid c)^* ((a b c) \mid (c b a)) (a \mid b \mid c)^*$
  - **#5:**  $(a^* b^* c^* a b c a^* b^* c^*) \mid (a^* b^* c^* c b a^* b^* c^*)$
  - **#6:**  $((a \mid b \mid c)^* a b c (a \mid b \mid c)^*) \mid ((a \mid b \mid c)^* c b a (a \mid b \mid c)^*)$

## (q2) Solutions

- Which of the REs below correspond to “All strings over alphabet  $\{a,b,c\}$  such that they contain at least one of substrings ‘abc’ or ‘cba’”?
  - #1:  $(abc)^+ \mid (cba)^+$
  - #2:  $(a \mid b \mid c)^* (a \mid c) b (a \mid c) (a \mid b \mid c)^*$
  - #3:  $(a \mid b \mid c)^* (a b c) (c b a) (a \mid b \mid c)^*$
  - #4:  $(a \mid b \mid c)^* ((a b c) \mid (c b a)) (a \mid b \mid c)^*$
  - #5:  $(a^* b^* c^* a b c a^* b^* c^*) \mid (a^* b^* c^* c b a^* b^* c^*)$
  - #6:  $((a \mid b \mid c)^* a b c (a \mid b \mid c)^*) \mid ((a \mid b \mid c)^* c b a (a \mid b \mid c)^*)$



## **(q3) Write a Regex**

- Write a RE for all binary strings that contains the substring 101 **or** the substring 000

## (q3) Solutions

- Write a RE for all binary strings that contains the substring 101 **or** the substring 000

$(0|1)^* 101 (0|1)^* |$   
 $(0|1)^* 000 (0|1)^*$

## (q4) Write a Regex

- Write a RE for all binary strings that contains the substring 101 **and** the substring 000

## (q4) Solutions

- Write a RE for all binary strings that contains the substring 101 **and** the substring 000

$(0|1)^* 101 (0|1)^* 000 (0|1)^* |$   
 $(0|1)^* 000 (0|1)^* 101 (0|1)^*$

# (q5) Pick the Regex

- Which of the REs below are for this automaton?

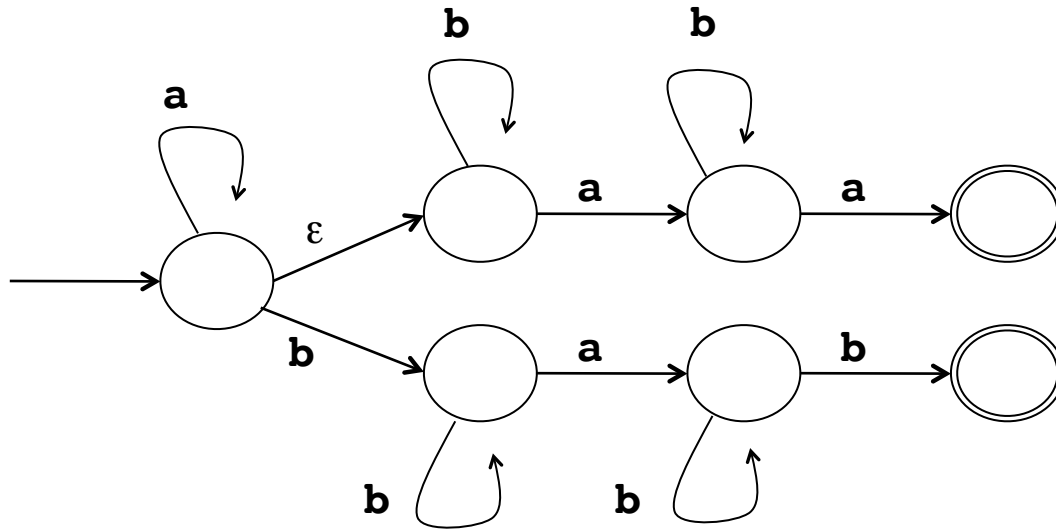

- #1:  $a^* b^* a b^* a$  |  $a^* b^+ a b^+$
- #2:  $a^* b^* a b^* a$  |  $a^* b^+ a b^*$
- #3:  $a^* b^+ a b^* a$  |  $a^* b^+ a b^+$
- #4:  $a^+ b^* a$  |  $a^* b^+ a b^+$

# (q5) Solutions

- Which of the REs below are for this automaton?

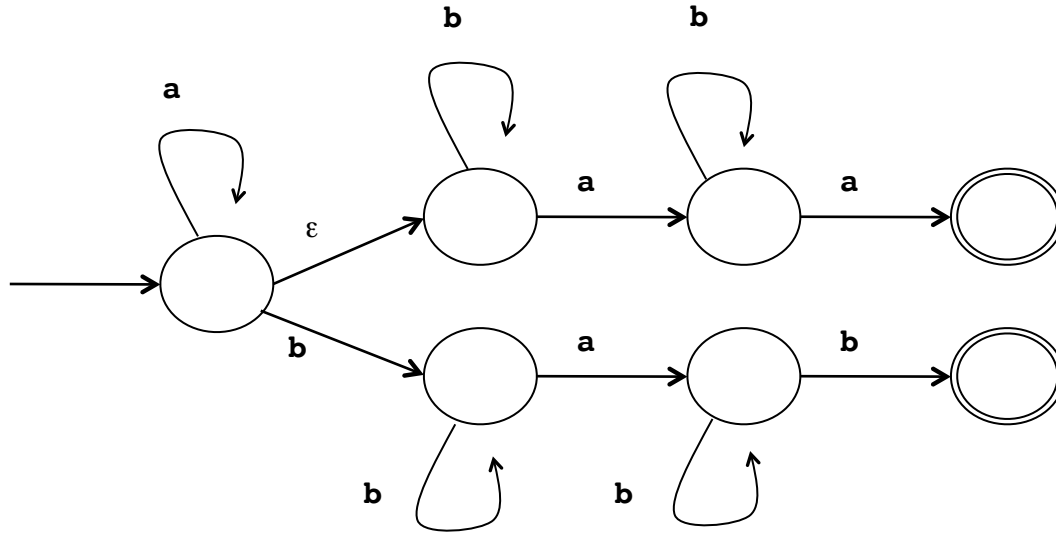

- #1:  $a^* b^* a b^* a$  |  $a^* b^+ a b^+$
- #2:  $a^* b^* a b^* a$  |  $a^* b^+ a b^*$
- #3:  $a^* b^+ a b^* a$  |  $a^* b^+ a b^+$
- #4:  $a^+ b^* a$  |  $a^* b^+ a b^+$

# (q6) Pick the Regex

- Which of the REs below are for this automaton?

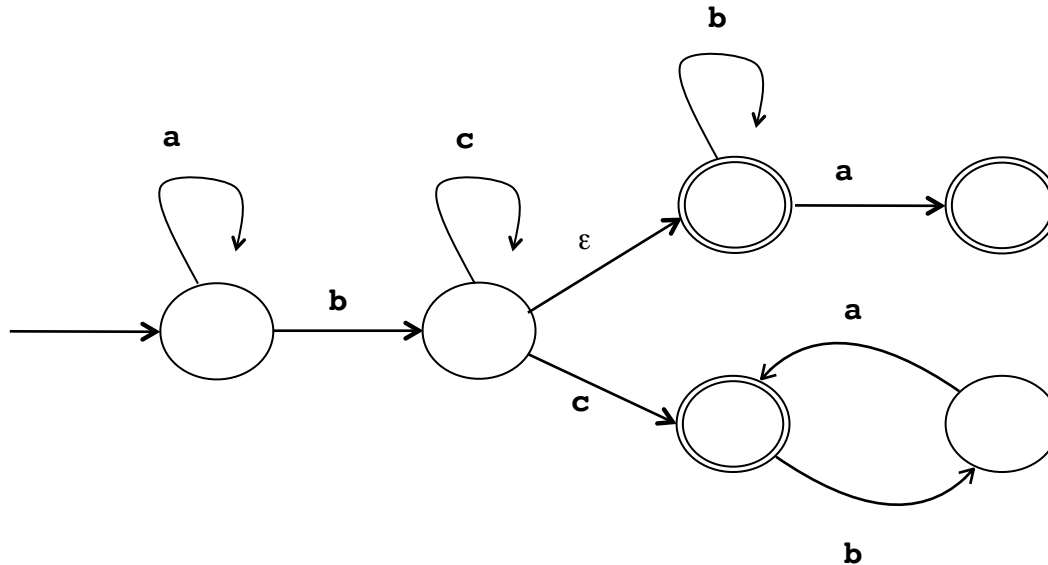

- #1:  $a^* b c^+ (b^* | b^* a | c b^* a^*)$
- #2:  $a^* b c^* (b^* a | c b^* a^*)$
- #3:  $a^* b c^* (b^* a? | c (b a)^*)$
- #4:  $a^* b c^* (b^* a | c (b a)^*)$

# (q6) Solutions

- Which of the REs below are for this automaton?

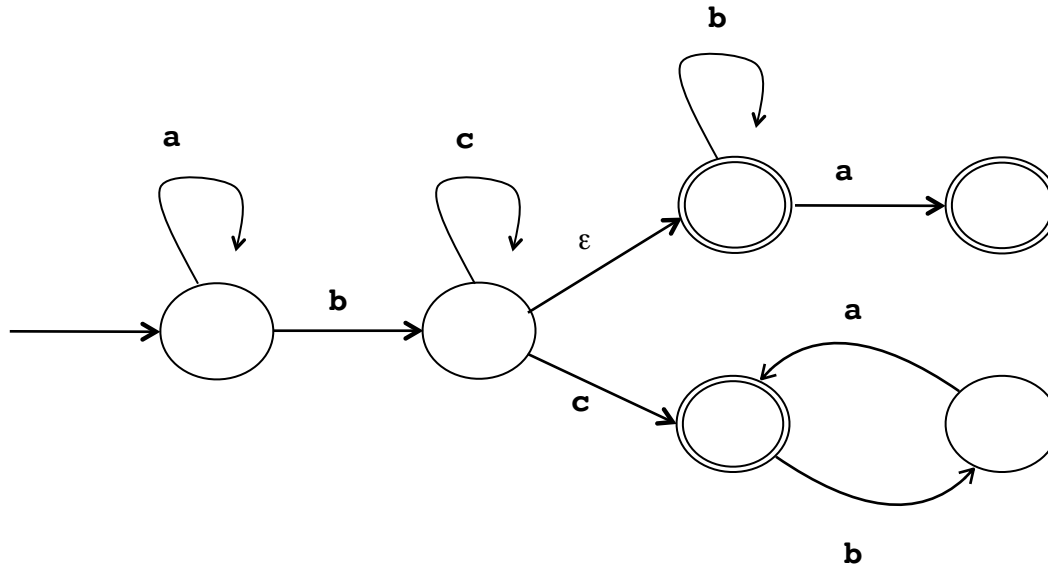

- #1:  $a^* b c^+ (b^* | b^* a | c b^* a^*)$
- #2:  $a^* b c^* (b^* a | c b^* a^*)$
- #3:  $a^* b c^* (b^* a? | c (b a)^*)$
- #4:  $a^* b c^* (b^* a | c (b a)^*)$

# (q7) Write a Regex

- Write an RE for this automaton

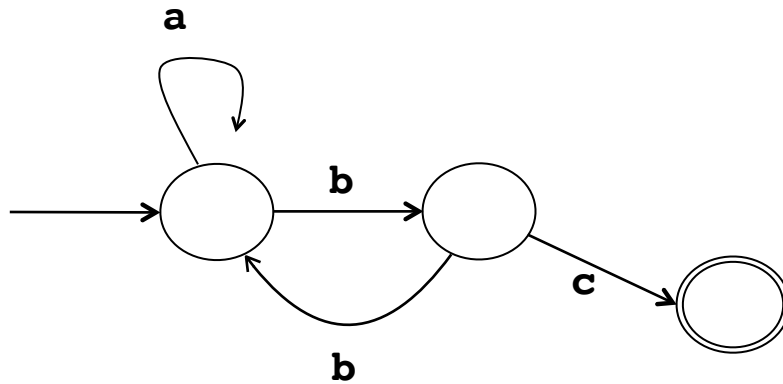

# (q7) Solutions

- Write an RE for this automaton

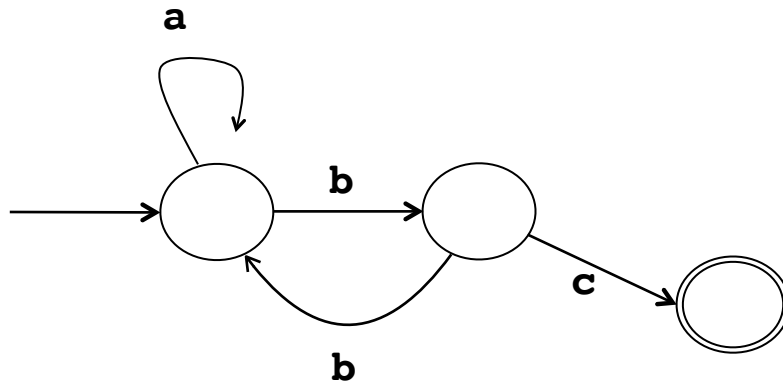

$(a^* bb)^* a^* b c$

# (q8) Write a Regex

- Write an RE for this automaton

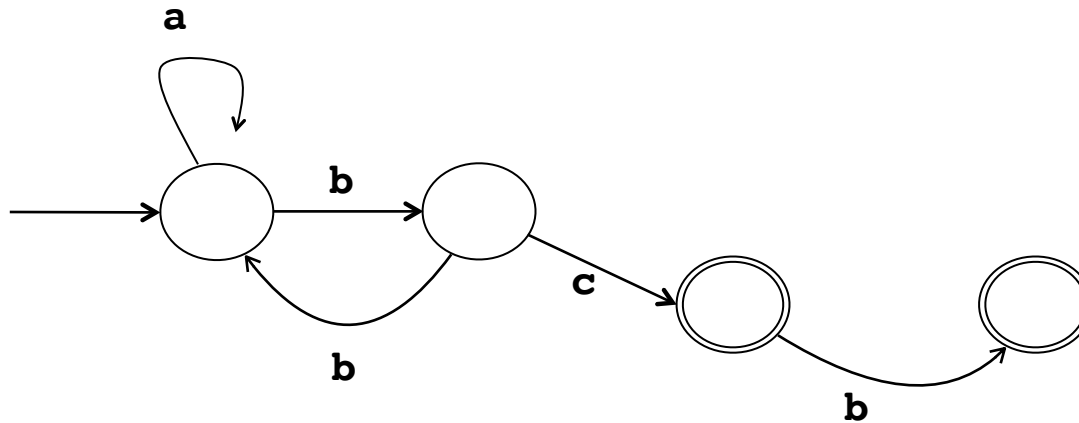

# (q8) Solutions

- Write an RE for this automaton

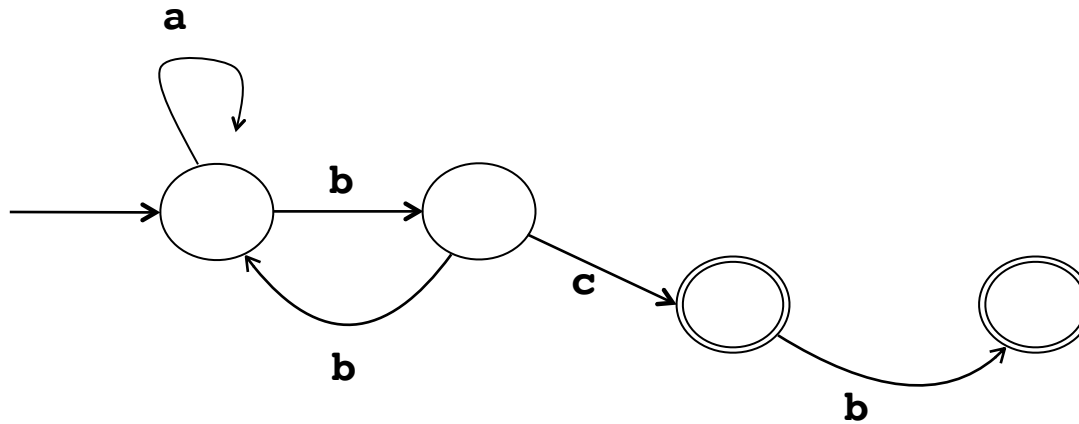

$(a^* bb)^* a^* b c b?$

# (q9) Write a Regex

- Write an RE for this automaton (not easy)

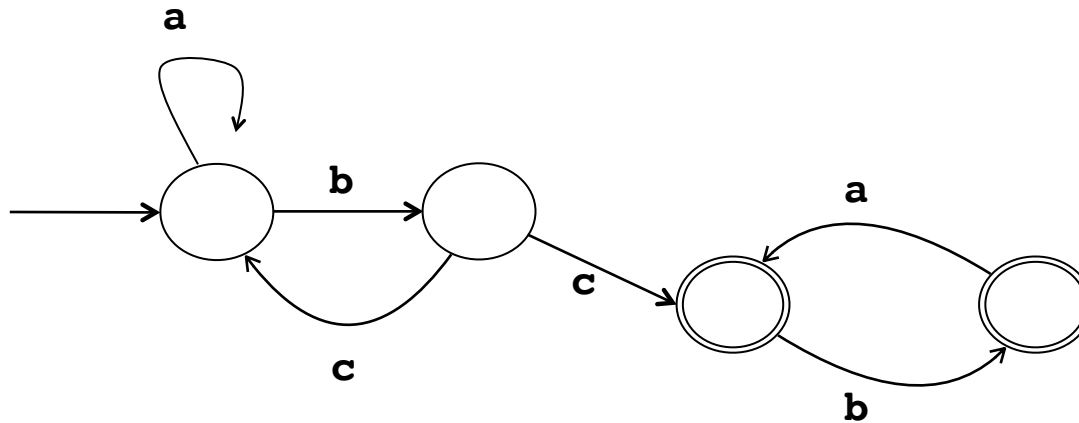

# (q9) Solutions

- Write an RE for this automaton (not easy)

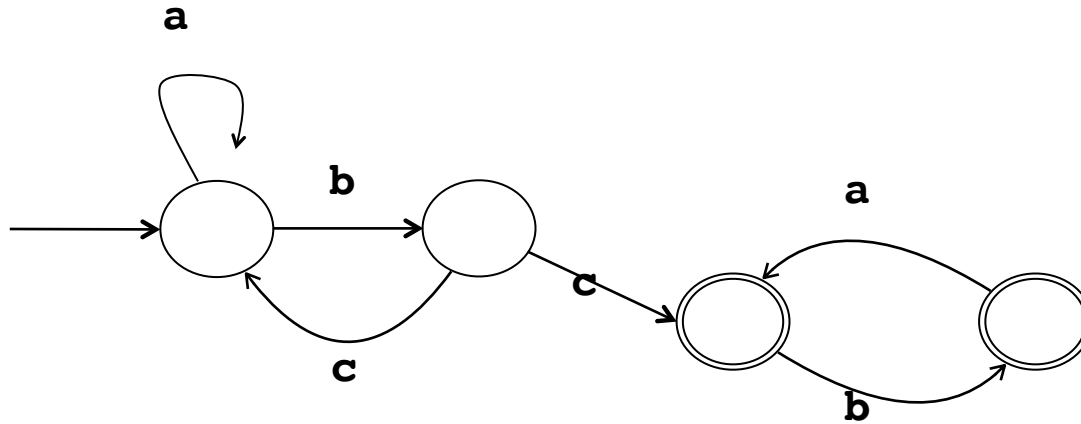

$(a^* b c)^* a^* b c (ba)^* b?$

## (q10) Draw an NFA

- Draw the NFA for:  $0^*1^+(0|1)0^*1$

# (q10) Solutions

- Draw the NFA for:  $0^*1^+(0|1)0^*1$

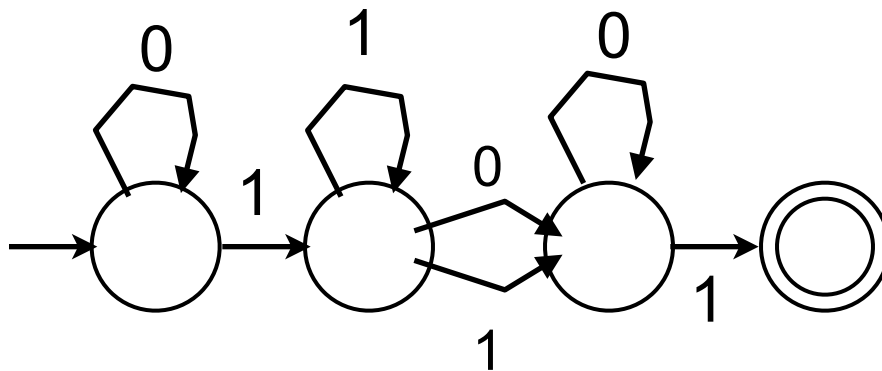

# (q11) Write a Regex

- Write the RE for this NFA

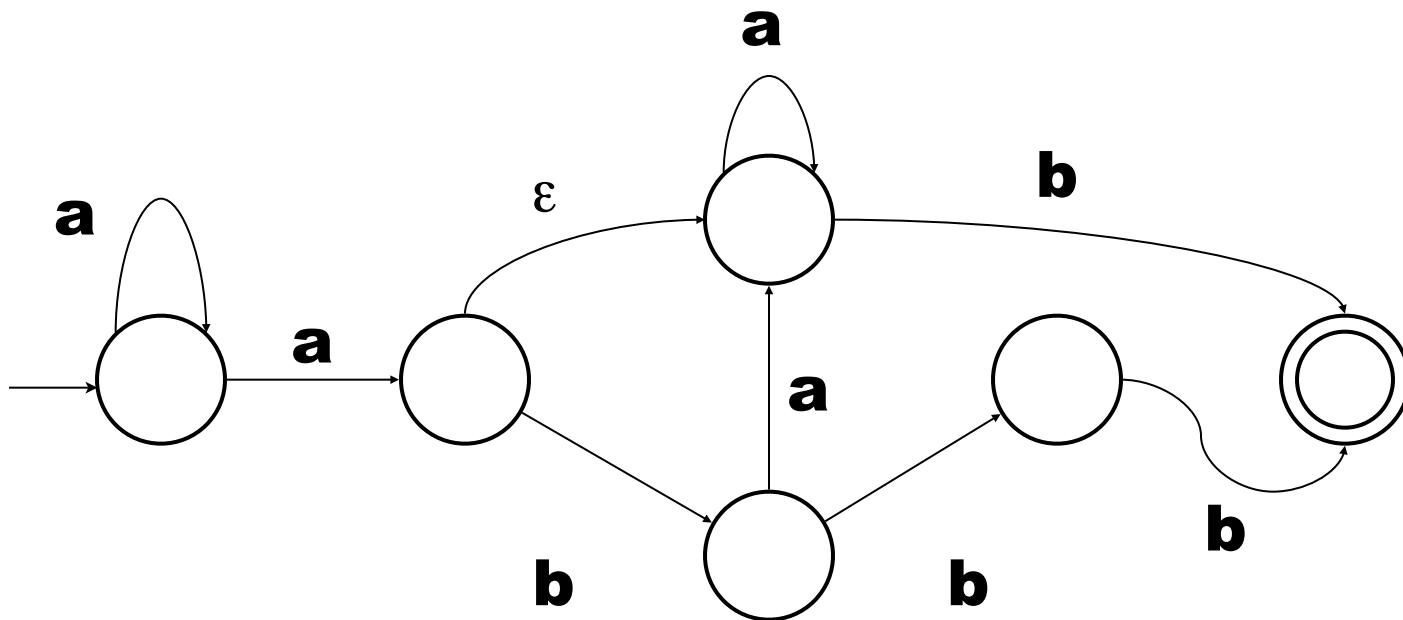

# (q11) Solutions

- Write the RE for this NFA

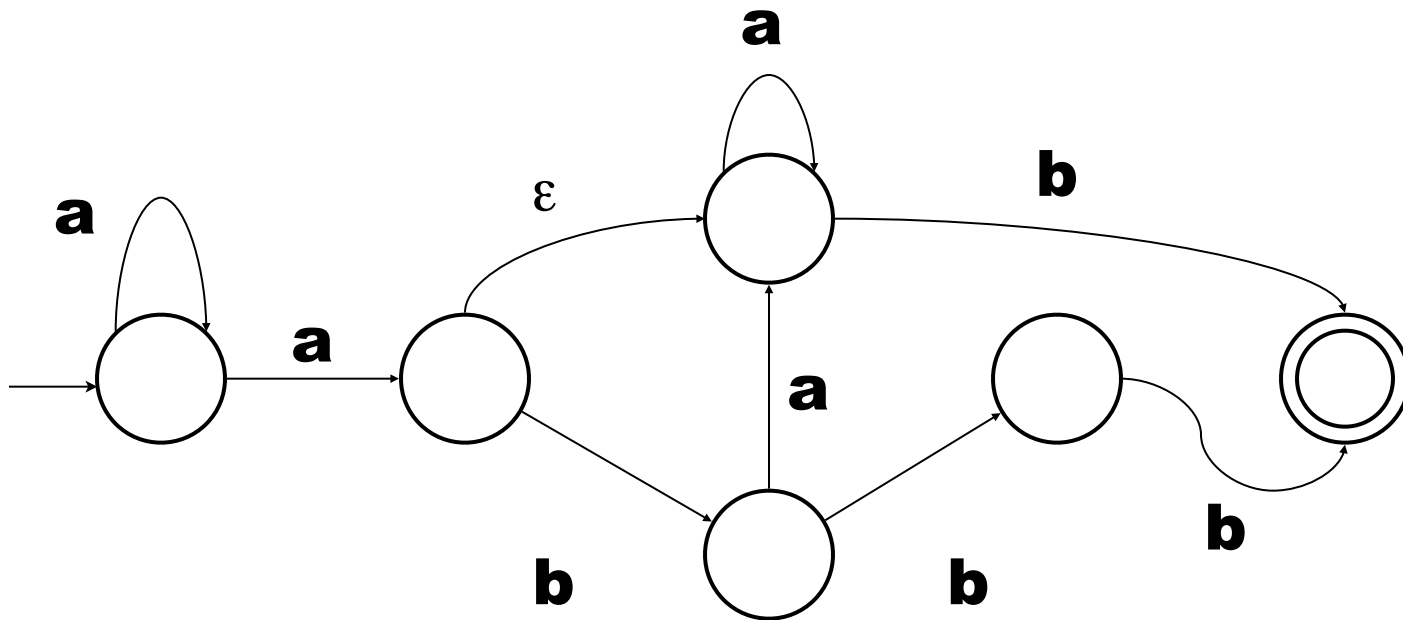

$$\begin{aligned} \text{RE} &= a^+a^*b \mid a^+ba^+b \mid a^+bbbb \\ &= a^+b \mid a^+ba^+b \mid a^+bbbb \\ &= a^+b(\epsilon \mid a^+b \mid bb) \end{aligned}$$